



SYSTEMS S3000

INDUSTRIAL CONTROLLER

S3075: DIGITAL AC OUTPUT 16 POINT 120VAC

FEATURES:

- 16 DIGITAL OUTPUT POINTS
- 2 INDIVIDUALLY ISOLATED SECTIONS OF 8 POINTS EACH
- .75 AMP DRIVE CAPABILITY PER OUTPUT POINT
- OUTPUT TRANSIENT PROTECTION/SNUBBER
- 16 INDIVIDUAL STATUS LAMPS (1 LAMP PER OUTPUT POINT)
- REMOVABLE FIELD WIRING CONNECTOR
- OPTICAL ISOLATION - BUS INTERFACE LOGIC TO OUTPUT
- STANDARD DOUBLE HEIGHT EUROCARD

GENERAL DESCRIPTION:

The S3075 120VAC Output Board contains 16 identical solid state circuits which convert the logic status of 2 output bytes, written from the Main Processor Board, to the appropriate voltage in order to drive user devices such as relays, solenoids, and lamps. On any given output point, writing a "1" to that point turns the output "on"; writing a "0" turns the output "off". When the output is "on", the voltage at the output is approximately equal to the users line voltage. When the output is "off", the voltage at the output is equal to the leakage current through the output snubber times the impedance of the output load. Heavier loads (200 to 1k ohms) will draw the output down to approximately 20Vrms while lighter loads (2k to 10k ohms) will only draw the output down to about 40Vrms. With no load connected, the voltage at the

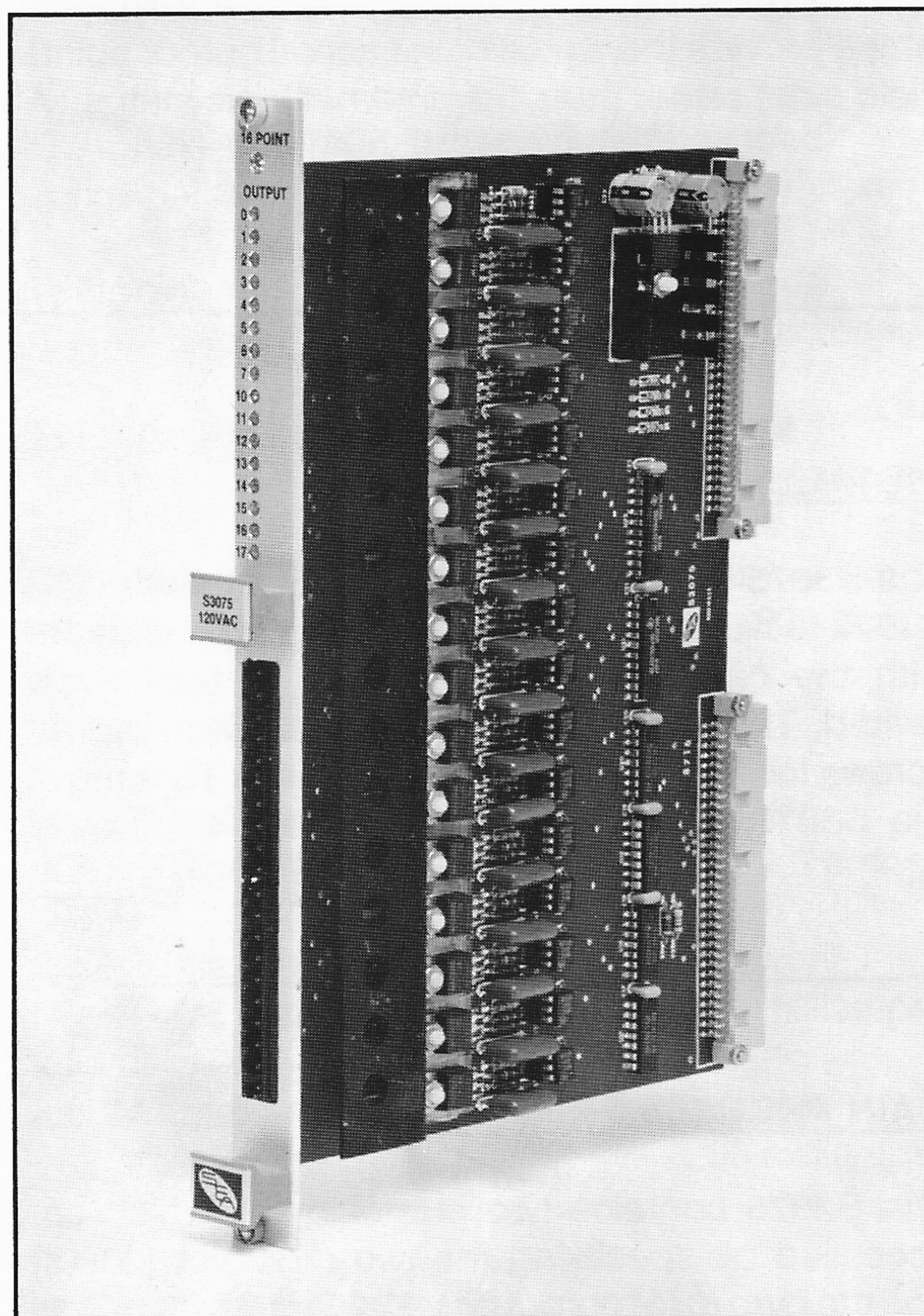

output would be measured as slightly less than the line voltage (120Vrms). For this reason, a minimum output load of 10k ohms is recommended for proper output operation.

The 16 outputs are split into two separate, isolated sections of eight points each. This allows two different user line sources (LINE and NEUTRAL) to be connected to the same output board.

Each output is rated at .75 amps rms (continuous) with an inrush current drive capability of 3 amps for 100msec. The sum of all outputs current cannot, however, exceed 8 amps. The S3075 does not contain output fusing, therefore external fusing at each output point and at the users LINE connection point should be provided. Refer to Figure 3 for an example of externally fusing the S3075.

Each output contains a transient suppression and snubber circuit which clamps any transient overvoltage to a level that will not damage the output circuitry. This allows solenoids and other inductive loads to be connected directly to an output point without connecting surge suppression devices to the load itself. All outputs are zero crossing turn on and turn off.

The on/off status of each output is indicated with individual neon lamps located on the faceplate. The lamps provide the status of the actual output points (field side) rather than the internal logic status. A

minimum load of 10k ohms is necessary for proper output lamp indication. If no load is connected, the neon lamp will be "on" whether the output is actually on or off. Outputs which are externally fused will also indicate an "on" condition if the fuse has blown. When the fuse blows, the output is isolated from the load and all leakage current through the output snubber circuit is then directed through the neon lamp of the output.

Output and user power wiring is implemented with a removable 20-pin field wiring connector which allows easy board replacement. Refer to Figure 3 for typical field wiring connections.

INSTALLATION:

The S3075 may be installed in any I/O slot of the S3000 rack. Install the S3075 by aligning the board with the card guides and sliding in until firmly seated. The board is held in the rack via captive screws located on the S3075 faceplate. To remove the S3075, loosen the captive screws and gently

pull the board out of the rack using the handles located on the S3075 faceplate.

NOTE: When installing or removing an S3075, the System should be in power-down mode (PS3007 power supply "off").

MAIN PROCESSOR INTERFACE:

The S3075 contains two output bytes which are accessed by specifying the two digit slot (00-15) and the byte (0 for output bits 00-07 and 1 for output bits 10-17).

When specified in the systems configuration of the main processor board the S3075 is automatically written to as part of the I/O update. The status of a variable type (Y) is written to the output. The format of this variable is:

output byte: Yaab

output bit: Yaab.c

Where: Y = output variable type (Y)

aa = two digit slot address
(00-15)

b = byte address
(0 for outputs 00-07,
1 for outputs 10-17)

c = bit address (0-7)

These variables are set in the user program and written to the S3075 during the I/O update at the beginning of the main program scan.

SPECIFICATIONS:

Number Of I/O Slots Required: 1

Board Size:

Length: 9.15"

Height: 6.30"

Width: 0.80"

Number Of I/O Points: 16

Number Of Isolated Sections: 2

Output Voltage:

Voltage Range: 120 volts rms

Vout(on-min) -minimum on voltage
(Iout=.75 amps): LINE-3.00 volts rms

Vout(on-max) -maximum on voltage
(Iout=.75 amps): LINE-0.75 volts rms

Vout(off-max)-maximum off voltage
(load=10k ohms): 50 volts rms

[Note: LINE = users line voltage (120VAC)]

Output Current:

Iout(max)-maximum continuous output current:
0.75 amps rms

Iout(min)-off state leakage current
(load=10k ohm): 5.00 milliamps

Iout(pul)-maximum pulsed output current
(t=100msec): 3.00 amps rms

Output Impedance (approximate):

Zout(on) -output on impedance: 0.50 ohms

Zout(off)-output off impedance: 2.5k ohms

Output Response Time:

Tplh(min)-minimum turn on time (max load):
10 microsec

Tplh(max)-maximum turn on time (max load):
8.33 millisecc

Tphl(min)-minimum turn off time (max load):
75 microsec

Tphl(max)-maximum turn off time (max load):
8.33 millisecc

Optical Isolation (bus interface to output):

1500 Vrms

Power Requirements (all outputs on):

IccEXT(max)-maximum allowed users line
current (line=120VAC): 8.0 amps

IccEXT(max)-maximum users supply current
(all outputs off): 200 milliamps

IccBUS(max)-maximum S3000 bus current:
200 milliamps

Temperature Ranges:

Storage: 0 to 85° C

Operating: 0 to 60° C

Relative Humidity:

5 to 95%

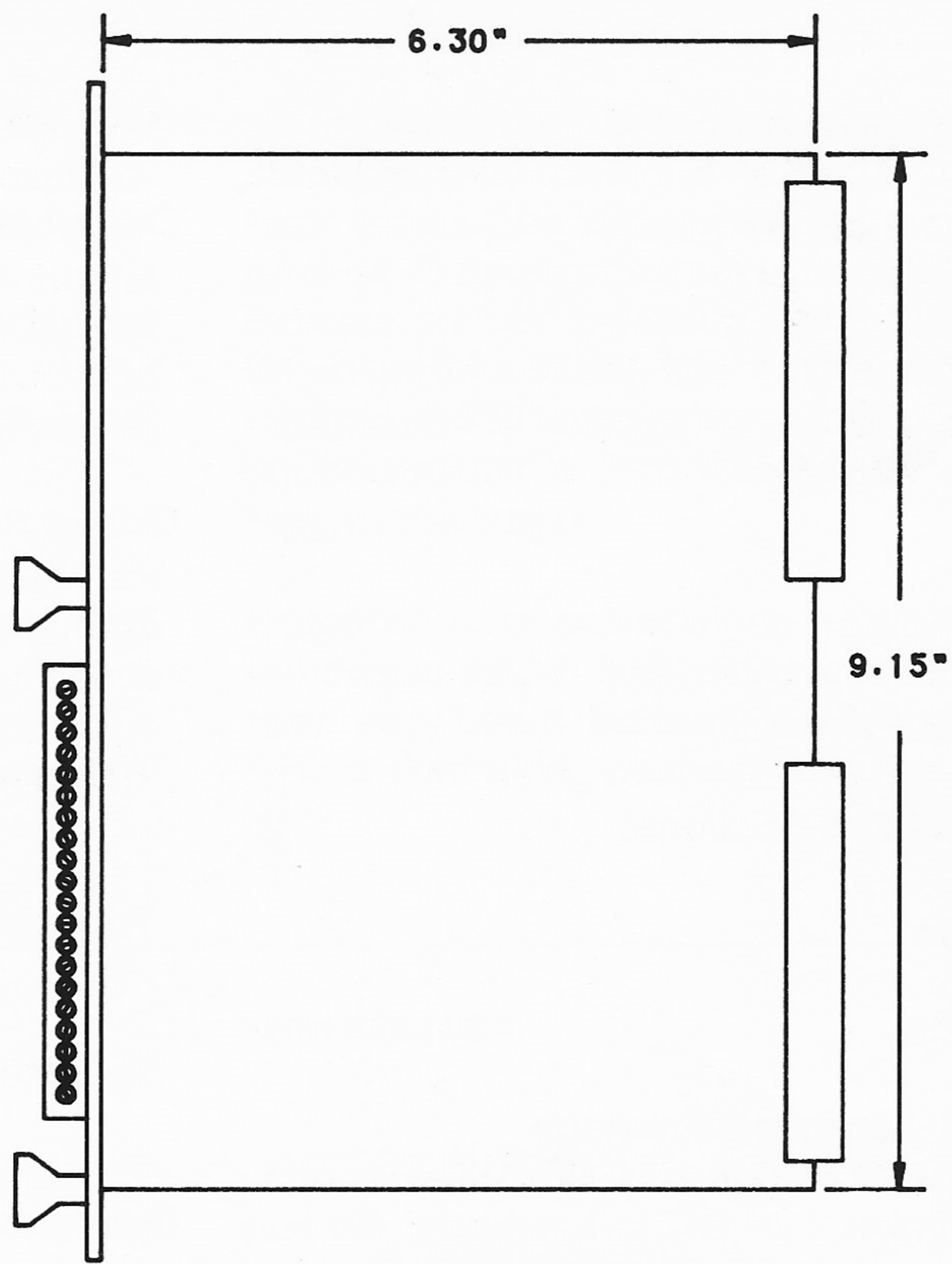
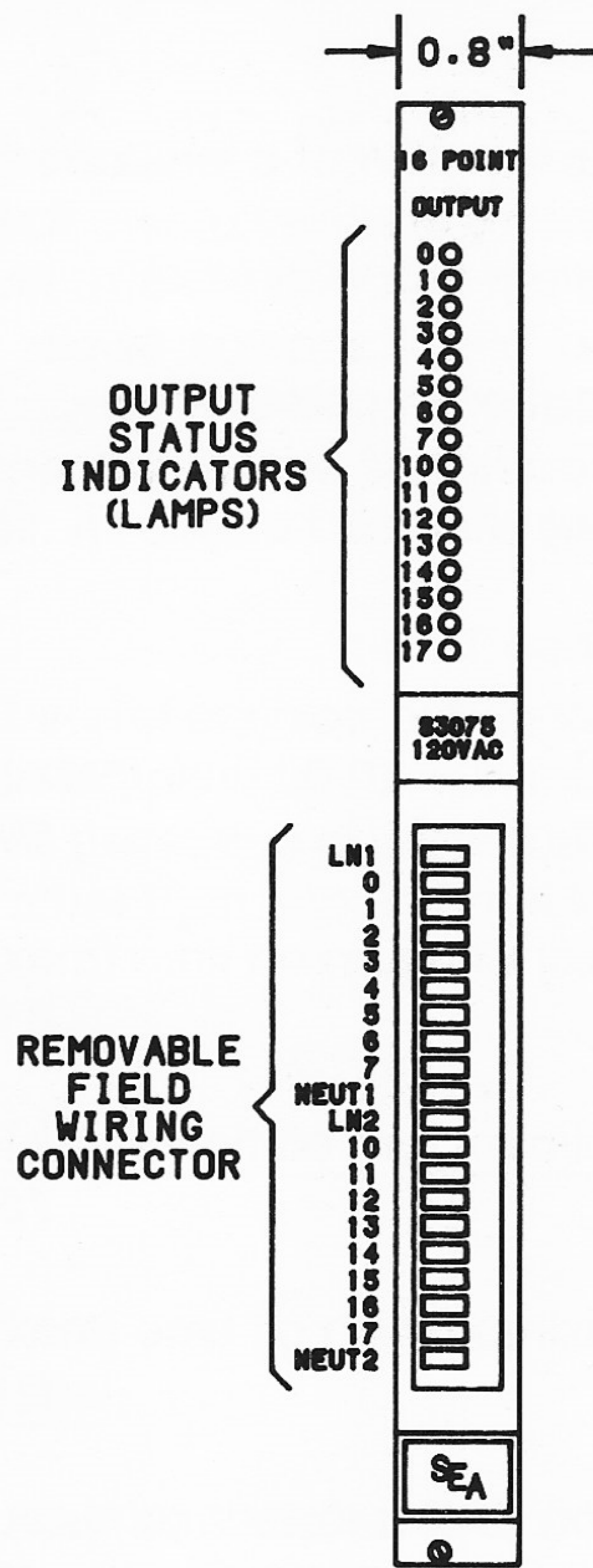

FIGURE 2
BOARD OUTLINE

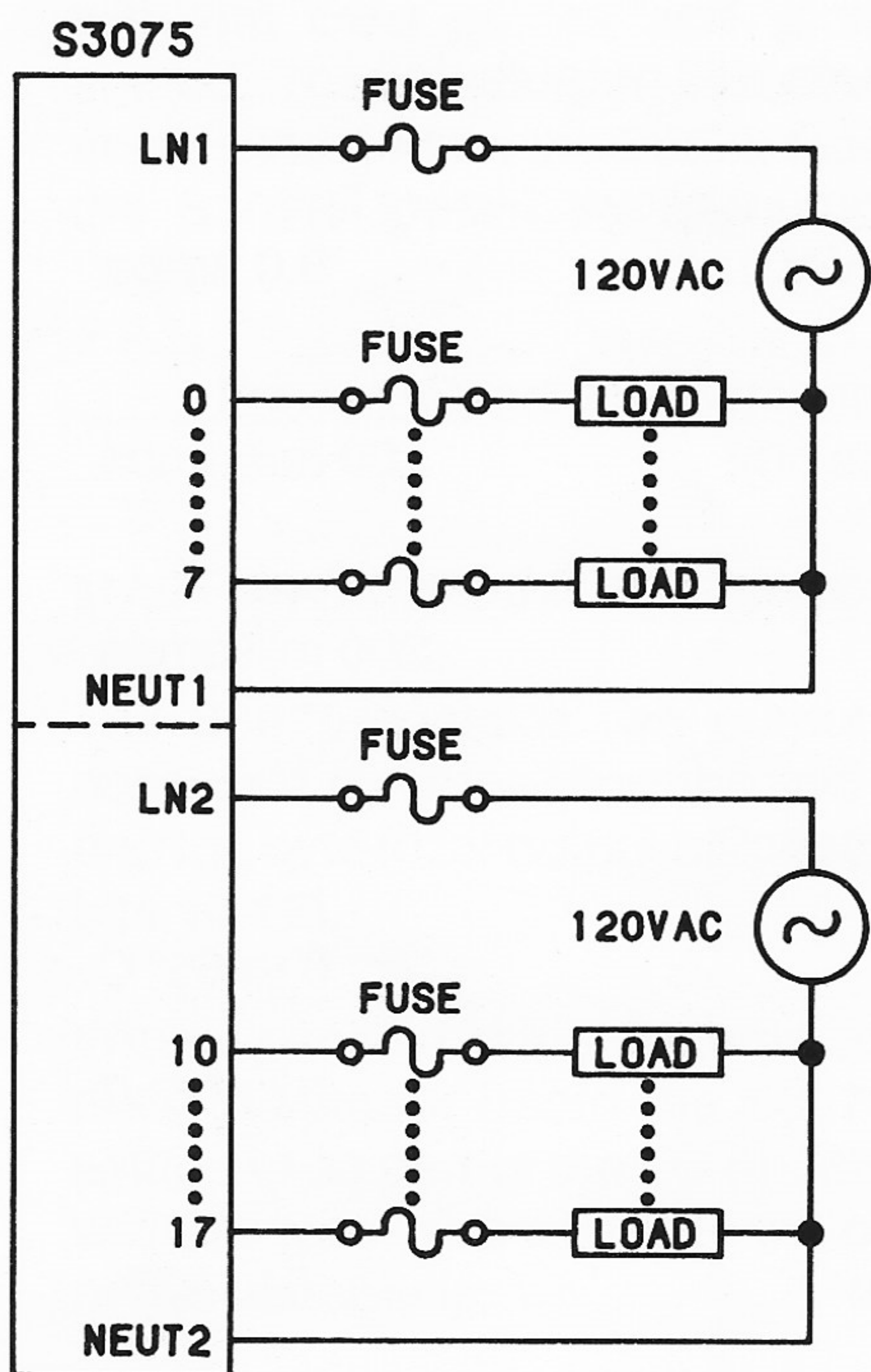

FIGURE 3
TYPICAL USER WIRING

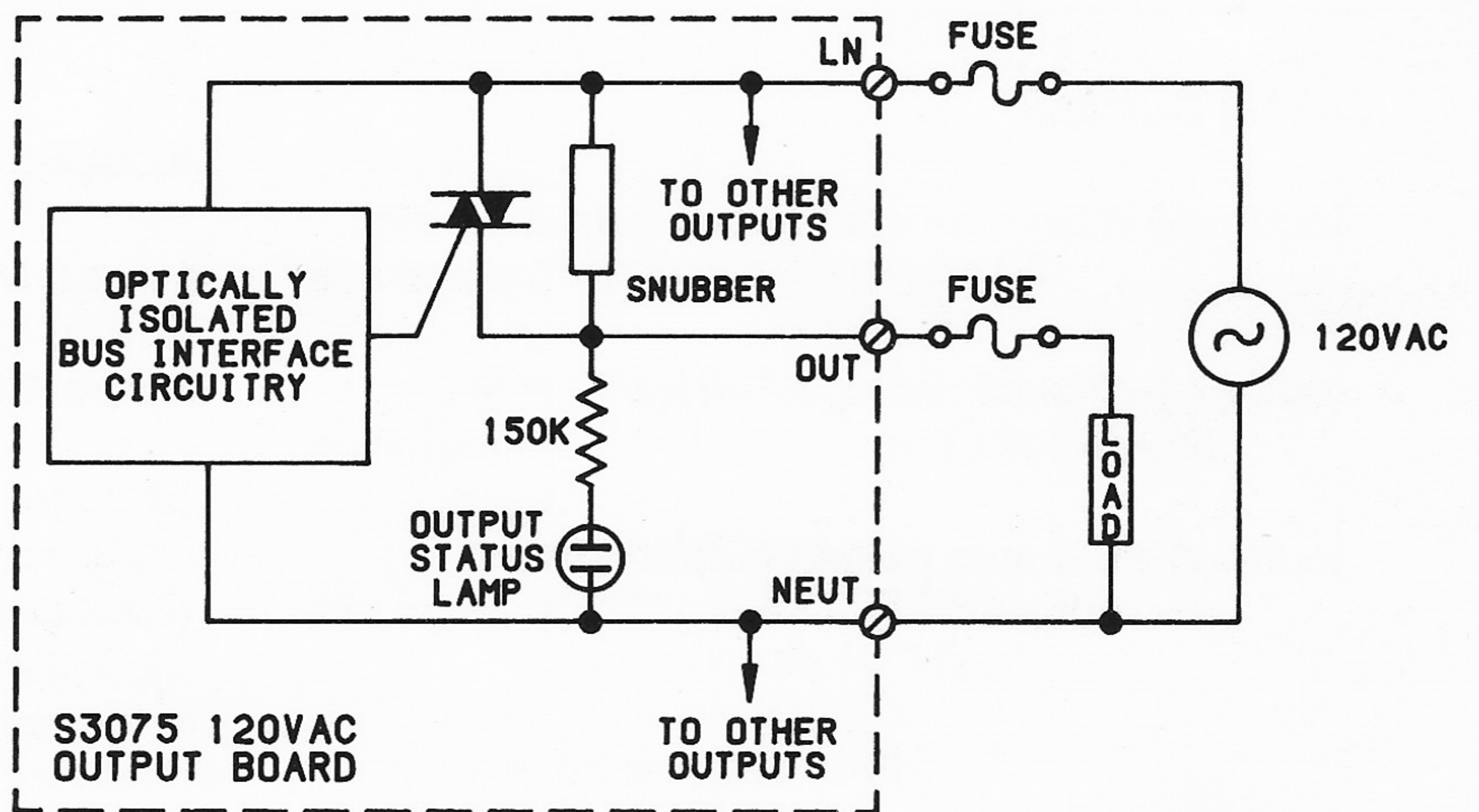

FIGURE 1
TYPICAL OUTPUT CIRCUIT



SYSTEMS ELECTRONICS GROUP

DIVISION OF SYSTEMS ENGINEERING ASSOCIATES, INC.
14989 W. 69TH AVE, ARVADA, COLORADO, P.O. BOX 750 80001
(303) 421-0233 FAX (303) 421-8108